

Asynchronous Multi-Context Systems¹

Stefan Ellmauthaler Jörg Pührer

Computer Science Institute
Leipzig University
Germany

ReactKnow 2014
Prague
August 19th 2014

¹Research has been supported by DFG and FWF (projects BR 1817/7-1 and FOR 1513)

- 1 Motivation
- 2 Concept
- 3 Asynchronous Multi-Context Systems
- 4 Relation to (reactive) Multi-Context Systems
- 5 Outlook & Related Work

Motivation

- **integration** of heterogeneous KR-formalisms
- **awareness** of continuous flow of knowledge

Motivation

- **integration** of heterogeneous KR-formalisms
- **awareness** of continuous flow of knowledge

Realisation

Motivation

- **integration** of heterogeneous KR-formalisms
- **awareness** of continuous flow of knowledge

Realisation

- **Contexts** with different KR & Reasoning formalisms
- **Bridge-Rules** for exchange of beliefs
- Notion of **Equilibrium** as Semantics
- **Run** represents the change of knowledge and belief over time

... and a slight look to online-applications

- Many different services and sources of knowledge
- Continuous flow of information
- Data collection till sufficient knowledge for their tasks is available
- Communication is often query-based
- Asynchronous communication protocols

... and a slight look to online-applications

- Data collection till sufficient knowledge for their tasks is available
- Communication is often query-based
- Asynchronous communication protocols

Example Environment - Emergency Team Management

- Emergency Call
- Classification and Prioritisation of each case
- Overview of available rescue units
- Overview on ETAs for each unit and case
- Suggesting optimal assignments
- Communicate Tasks to rescue units

Computer Aided Emergency Team Management

Example Environment - Emergency Team Management

- Emergency Call
- Classification and Prioritisation of each case
- Overview of available rescue units
- Overview on ETAs for each unit and case
- Suggesting optimal assignments
- Communicate Tasks to rescue units

Requirements

- Fast response to events
- Consider different sources of data
- Modularity for additional components
- Human as last instance for decisions

Consequences of Asynchronicity

→ Contexts compute their belief sets independently

Consequences of Asynchronicity

- Contexts compute their belief sets independently
- No agreement on a common Equilibrium

Consequences of Asynchronicity

- Contexts compute their belief sets independently
- No agreement on a common Equilibrium
 - No defined basis for Bridge-Rules to fire

Consequences of Asynchronicity

- Contexts compute their belief sets independently
- No agreement on a common Equilibrium
 - No defined basis for Bridge-Rules to fire
 - Need for Output-Rules (OR)

Consequences of Asynchronicity

- Contexts compute their belief sets independently
- No agreement on a common Equilibrium
 - No defined basis for Bridge-Rules to fire
 - Need for Output-Rules (OR)
 - Keep track of information provided by OR

Consequences of Asynchronicity

- Contexts compute their belief sets independently
- No agreement on a common Equilibrium
 - No defined basis for Bridge-Rules to fire
 - Need for Output-Rules (OR)
 - Keep track of information provided by OR
 - Input stream for each context

Consequences of Asynchronicity

- Contexts compute their belief sets independently
- No agreement on a common Equilibrium
 - No defined basis for Bridge-Rules to fire
 - Need for Output-Rules (OR)
 - Keep track of information provided by OR
 - Input stream for each context
 - Interaction with environment:
 - ▶ aMCS wide input streams
 - ▶ aMCS wide output streams

- Each context decide when to compute
 - ▶ realised by computation controller cc
- Dynamic adjustments of context-management
 - ▶ computation controller (cc)
 - ▶ output rules (OR)
 - ▶ context-semantics (ACC)
 - ▶ context update function (cu)

Definition

A *data package* is a pair $d = \langle s, I \rangle$, where $s \in \mathcal{N}$ is either a context name or a sensor name, stating the *source* of d , and $I \subseteq \mathcal{IL}$ is a set of pieces of information. An *information buffer* is a sequence of data packages.

Asynchronous Multi-Context Systems

Definition

A *data package* is a pair $d = \langle s, I \rangle$, where $s \in \mathcal{N}$ is either a context name or a sensor name, stating the *source* of d , and $I \subseteq \mathcal{IL}$ is a set of pieces of information. An *information buffer* is a sequence of data packages.

Definition

Let $C = \langle n, \mathcal{LS} \rangle$ be a context. An *output rule* r for C is an expression of the form

$$\langle n, i \rangle \leftarrow b_1, \dots, b_j, \text{not } b_{j+1}, \dots, \text{not } b_m, \quad (1)$$

such that $n \in \mathcal{N}$ is the name of a context or an output stream, $i \in \mathcal{IL}$ is a piece of information, and every b_ℓ ($1 \leq \ell \leq m$) is a belief for C , i.e., $b_\ell \in S$ for some $S \in \mathcal{BS}_{\mathcal{LS}}$.

Definition

Let $C = \langle n, \mathcal{LS} \rangle$ be a context, OR a set of output rules for C , $S \in \mathcal{BS}_{\mathcal{LS}}$ a belief set, and $n' \in \mathcal{N}$ a name. Then, the data package

$$d_C(S, OR, n') = \langle n, \{i \mid r \in OR, hd(r) = \langle n', i \rangle, S \models bd(r)\} \rangle$$

is the *output* of C with respect to OR under S relevant for n .

Definition

Let $C = \langle n, \mathcal{LS} \rangle$ be a context. A *configuration* of C is a tuple $cf = \langle \text{KB}, \text{ACC}, \text{ib}, cm \rangle$, where $\text{KB} \in \mathcal{KB}_{\mathcal{LS}}$, $\text{ACC} \in \mathcal{ACC}_{\mathcal{LS}}$, ib is a finite information buffer, and cm is a *context management* for C which is a triple $cm = \langle cc, cu, \text{OR} \rangle$, where

- cc is a computation controller for C ,
- OR is a set of output rules for C , and
- cu is a *context update function* for C which is a function that maps an information buffer $\text{ib} = d_1, \dots, d_m$ and an admissible knowledge base of \mathcal{LS} to a configuration $cf' = \langle \text{KB}', \text{ACC}', \text{ib}', cm' \rangle$ of C with $\text{ib}' = d_k, \dots, d_m$ for some $k \geq 1$.

Asynchronous Multi-Context Systems

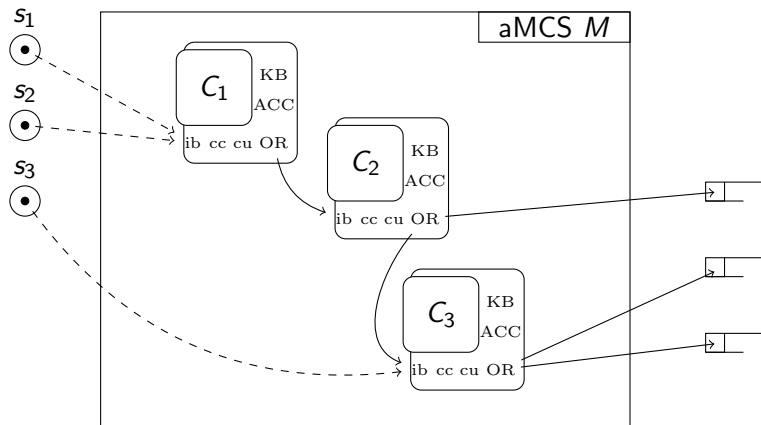

Configuration of an aMCS

- Configuration for each Context
- Content of each output stream (output buffer)

Run of an aMCS

Configuration of an aMCS

- Configuration for each Context
- Content of each output stream (output buffer)

Definition (Run structure)

Let $M = \langle \langle C_1, \dots, C_n \rangle, \langle o_1, \dots, o_m \rangle \rangle$ be an aMCS. A run structure for M is a sequence

$$R = \dots, Cf^t, Cf^{t+1}, Cf^{t+2}, \dots,$$

where $t \in \mathbb{Z}$ is a point in time, and every $Cf^{t'}$ in R ($t' \in \mathbb{Z}$) is a configuration of M .

Run of an aMCS

Time-awareness

- Computation of belief sets takes time
- Enumeration of belief sets takes time
- Verification of non-existence of (further) belief sets takes time

Run execution

- If a Context finds a belief set, OR are applied
- Information is distributed to input-buffers of contexts or output streams
- If a Context has finished its computation, EOC is sent to all stakeholders

Example of an aMCS

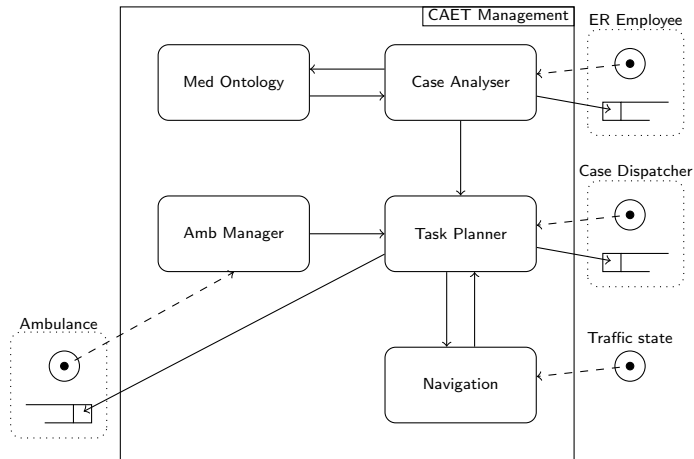

- rMCSs use equilibria
 - ▶ strong semantics
 - ▶ tight integration approach where context semantics are interdependent
 - ▶ every context need to agree → each context needs to wait

- rMCSs use equilibria
 - ▶ strong semantics
 - ▶ tight integration approach where context semantics are interdependent
 - ▶ every context need to agree → **synchronous** approach

- rMCSs use equilibria
 - ▶ strong semantics
 - ▶ tight integration approach where context semantics are interdependent
 - ▶ every context need to agree → [synchronous](#) approach
- rMCSs have equilibria as source of non-determinism
- aMCSs have computation time as source of non-determinism

- For each Context C_i of the rMCS, introduce three aMCS Contexts:
 - ▶ C_i^{kb} stores its current knowledge base
 - ▶ $C_i^{kb'}$ stores update of the knowledge base and compute its semantics
 - ▶ C_i^m implements the bridge rules and the management function

Simulation of rMCS

- For each Context C_i of the rMCS, introduce three aMCS Contexts:
 - ▶ C_i^{kb} stores its current knowledge base
 - ▶ $C_i^{kb'}$ stores update of the knowledge base and compute its semantics
 - ▶ C_i^m implements the bridge rules and the management function
- Three contexts for the rMCS, where
 - ▶ C^{obs} receives sensor data and distributes the information,
 - ▶ C^{guess} guesses equilibrium candidates and propagates them to C_i^m , and
 - ▶ C^{check} compares all results of the contexts and informs other contexts if an equilibrium has been found

- Study modelling patterns and best practices for aMCS
- Analysis how other approaches (e.g., `clingo` [Gebser et al., 2012]) are capable for prototypical implementations
- Analysis how features of other approaches (e.g., online queries, iterative computing, ...) relate to aMCS concepts (e.g., `ib`, `OR,cc`, ...)

- aMCS are motivated by rMCS [Brewka et al., 2014] and are based on MCS [Brewka et al., 2011a, Brewka et al., 2011b]
- Evolving Multi-Context Systems [Gonçalves et al., 2014] follow a similar approach to rMCS
- A concept similar for output rules in reactive Multi-Context Systems has been presented as reactive bridge rules [Ellmauthaler, 2013]

Thank you for your interest!

- [Brewka et al., 2011a] Brewka, G., Eiter, T., and Fink, M. (2011a).
Nonmonotonic multi-context systems: A flexible approach for
integrating heterogeneous knowledge sources.
In Logic Programming, Knowledge Representation, and Nonmonotonic Reasoning, pages 233–258. Springer.
- [Brewka et al., 2011b] Brewka, G., Eiter, T., Fink, M., and Weinzierl, A.
(2011b).
Managed multi-context systems.
In IJCAI'11, pages 786–791.
- [Brewka et al., 2014] Brewka, G., Ellmauthaler, S., and Pührer, J. (2014).
Multi-context systems for reactive reasoning in dynamic environments.
In Proc. ECAI'14.
To appear.

- [Ellmauthaler, 2013] Ellmauthaler, S. (2013).
Generalizing multi-context systems for reactive stream reasoning applications.
In *Proc. ICCSW'13*, pages 17–24.
- [Gebser et al., 2012] Gebser, M., Grote, T., Kaminski, R., Obermeier, P., Sabuncu, O., and Schaub, T. (2012).
Stream reasoning with answer set programming: Preliminary report.
In *Proc. KR'12*.
- [Gonçalves et al., 2014] Gonçalves, R., Knorr, M., and Leite, J. (2014).
Evolving multi-context systems.
In *Proc. ECAI'14*.
To appear.

Definition

A context is a pair $C = \langle n, \mathcal{LS} \rangle$ where $n \in \mathcal{N}$ is the name of the context and \mathcal{LS} is a logic suite.

Definition

An aMCS (of length n with m output streams) is a pair $M = \langle C, O \rangle$, where $C = \langle C_1, \dots, C_n \rangle$ is an n -tuple of contexts and $O = \langle o_1, \dots, o_m \rangle$ with $o_j \in \mathcal{N}$ for each $1 \leq j \leq m$ is a tuple containing the names of the output streams of M .

Definition

A *data package* is a pair $d = \langle s, I \rangle$, where $s \in \mathcal{N}$ is either a context name or a sensor name, stating the *source* of d , and $I \subseteq \mathcal{IL}$ is a set of pieces of information. An *information buffer* is a sequence of data packages.

Definition

Let $C = \langle n, \mathcal{LS} \rangle$ be a context. A *computation controller* for C is a relation cc between a KB $KB \in \mathcal{KB}_{\mathcal{LS}}$ and a finite information buffer.

Definition

Let $C = \langle n, \mathcal{LS} \rangle$ be a context. An *output rule* r for C is an expression of the form

$$\langle n, i \rangle \leftarrow b_1, \dots, b_j, \text{not } b_{j+1}, \dots, \text{not } b_m, \quad (2)$$

such that $n \in \mathcal{N}$ is the name of a context or an output stream, $i \in \mathcal{IL}$ is a piece of information, and every b_ℓ ($1 \leq \ell \leq m$) is a belief for C , i.e., $b_\ell \in S$ for some $S \in \mathcal{BS}_{\mathcal{LS}}$.

Definition

Let $C = \langle n, \mathcal{LS} \rangle$ be a context, OR a set of output rules for C , $S \in \mathcal{BS}_{\mathcal{LS}}$ a belief set, and $n' \in \mathcal{N}$ a name. Then, the data package

$$d_C(S, OR, n') = \langle n, \{i \mid r \in OR, hd(r) = \langle n', i \rangle, S \models bd(r)\} \rangle$$

is the *output* of C with respect to OR under S relevant for n .

Definition

Let $C = \langle n, \mathcal{LS} \rangle$ be a context. A *configuration* of C is a tuple $cf = \langle \text{KB}, \text{ACC}, \text{ib}, cm \rangle$, where $\text{KB} \in \mathcal{KB}_{\mathcal{LS}}$, $\text{ACC} \in \mathcal{ACC}_{\mathcal{LS}}$, ib is a finite information buffer, and cm is a *context management* for C which is a triple $cm = \langle cc, cu, \text{OR} \rangle$, where

- cc is a computation controller for C ,
- OR is a set of output rules for C , and
- cu is a *context update function* for C which is a function that maps an information buffer $\text{ib} = d_1, \dots, d_m$ and an admissible knowledge base of \mathcal{LS} to a configuration $cf' = \langle \text{KB}', \text{ACC}', \text{ib}', cm' \rangle$ of C with $\text{ib}' = d_k, \dots, d_m$ for some $k \geq 1$.

Definition

Let $M = \langle \langle C_1, \dots, C_n \rangle, \langle o_1, \dots, o_m \rangle \rangle$ be an aMCS. A *configuration* of M is a pair

$$Cf = \langle \langle cf_1, \dots, cf_n \rangle, \langle ob_1, \dots, ob_m \rangle \rangle,$$

where

- for all $1 \leq i \leq n$ $cf_i = \langle \text{KB}, \text{ACC}, \text{ib}, \text{cm} \rangle$ is a configuration for C_i and for every output rule $r \in \text{OR}_{\text{cm}}$ we have $n \in \mathcal{N}(M)$ for $\langle n, i \rangle = \text{hd}(r)$, and
- $ob_j = \dots, d_{l-1}, d_l$ is an information buffer with a final element d_l that corresponds to the data on the output stream named o_j for each $1 \leq j \leq m$ such that for each $h \leq l$ with $d_h = \langle n, i \rangle$ we have $n = n_{C_i}$ for some $1 \leq i \leq n$.

Definition

Let $M = \langle\langle C_1, \dots, C_n \rangle, \langle o_1, \dots, o_m \rangle\rangle$ be an aMCS. A run structure for M is a sequence

$$R = \dots, Cf^t, Cf^{t+1}, Cf^{t+2}, \dots,$$

where $t \in \mathbb{Z}$ is a point in time, and every $Cf^{t'}$ in R ($t' \in \mathbb{Z}$) is a configuration of M .

Definition

Let M be an aMCS of length n with m output streams and R a run structure for M . R is a *run* for M if the following conditions hold for every $1 \leq i \leq n$ and every $1 \leq j \leq m$:

- (i) if cf_i^t and cf_i^{t+1} are defined, C_i is neither busy nor waiting at time t , then
- ▶ C_i is busy at time $t + 1$,
 - ▶ $cf_i^{t+1} = cu_{cm_i^t}(ib_i^t, KB_i^t)$

We say that C_i *started a computation* for KB_i^{t+1} at time $t + 1$.

- (ii) if C_i *started a computation* for KB at time t then
- ▶ we say that this computation ended at time t' , if t' is the earliest time point with $t' \geq t$ such that $\langle n_{C_i}, \text{EOC} \rangle$ is added to every stakeholder buffer b of C_i at t' ; the addition of $d_{C_i}(S, \text{OR}_{cm_i^{t'}}, n)$ to b is called an *end of computation notification*.
 - ▶ for all $t' > t$ such that $cf_i^{t'}$ is defined, C_i is busy at t' unless the computation ended at some time t'' with $t < t'' < t'$.
 - ▶ if the computation ended at time t' and $cf_i^{t'+1}$ is defined then C_i is not busy at $t' + 1$.

Definition

- (iii) if C_i started a computation for KB at time t that ended at time t' then for every belief set $S \in \text{ACC}_i^t$ there is some time t'' with $t \leq t'' \leq t'$ such that
- ▶ $d_{C_i}(S, \text{OR}_{cm_i^{t''}}, n)$ is added to every stakeholder buffer b of C_i for n at t'' .

We say that C_i computed S at time t'' . The addition of $d_{C_i}(S, \text{OR}_{cm_i^{t''}}, n)$ to b is called a *belief set notification*.

- (iv) if obj_j^t and obj_j^{t+1} are defined and $\text{obj}_j^t = \dots, d_{l-1}, d_l$ then $\text{obj}_j^{t+1} = \dots, d_{l-1}, d_l, \dots, d_{l'}$ for some $l' \geq l$. Moreover, every data package $d_{l''}$ with $l < l'' \leq l'$ that was added at time $t + 1$ results from an end of computation notification or a belief set notification.
- (v) if cf_i^t and cf_i^{t+1} are defined, C_i is busy or waiting at time t , and $\text{ib}_i^t = d_1, \dots, d_l$ then we have $\text{ib}_i^{t+1} = d_1, \dots, d_l, \dots, d_{l'}$ for some $l' \geq l$. Moreover, every data package $d_{l''}$ with $l < l'' \leq l'$ that was added at time $t + 1$ either results from an end of computation notification or a belief set notification or $n \notin \mathcal{N}(M)$ (i.e., n is a sensor name) for $d_{l''} = \langle n, i \rangle$.